

--	--	--	--

! ž

--	--	--	--

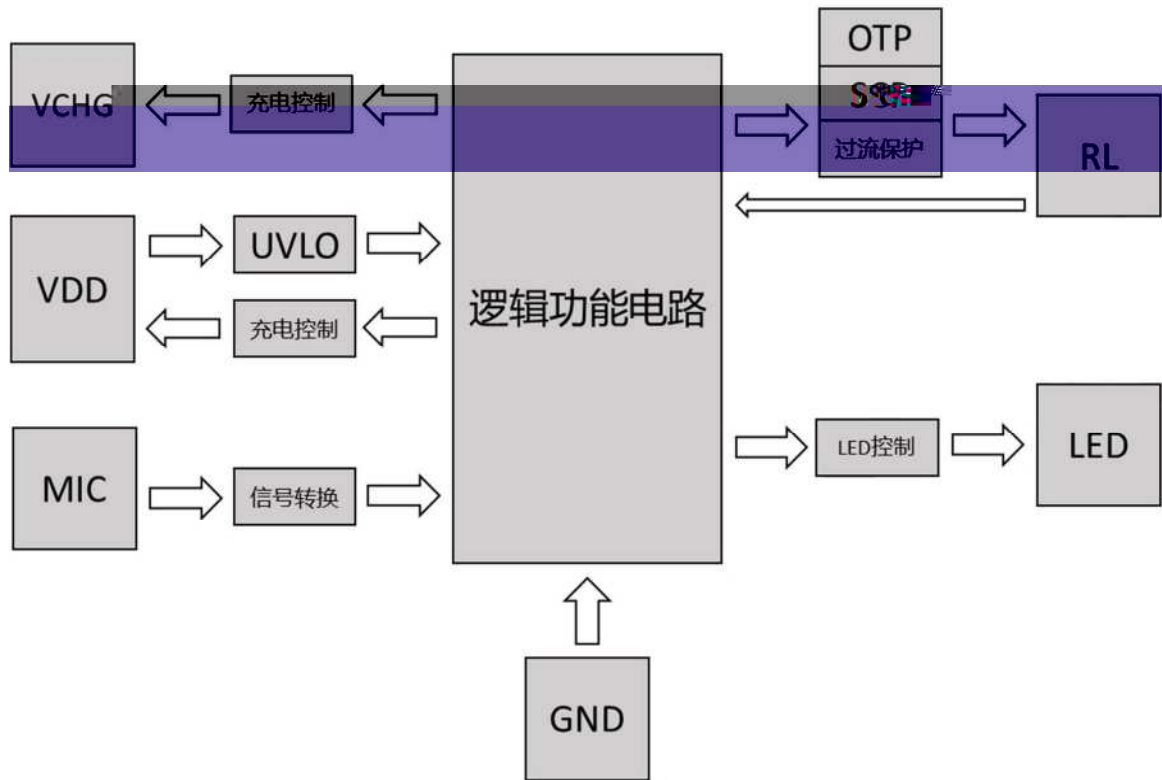

外形	序号	符号	功能描述
	1	VCHG	充电电源输入
	2	GND	地
	3	MIC	吸烟检测 (SENSOR)
	5	VOUT	接电热丝
	6	VDD	电池正端

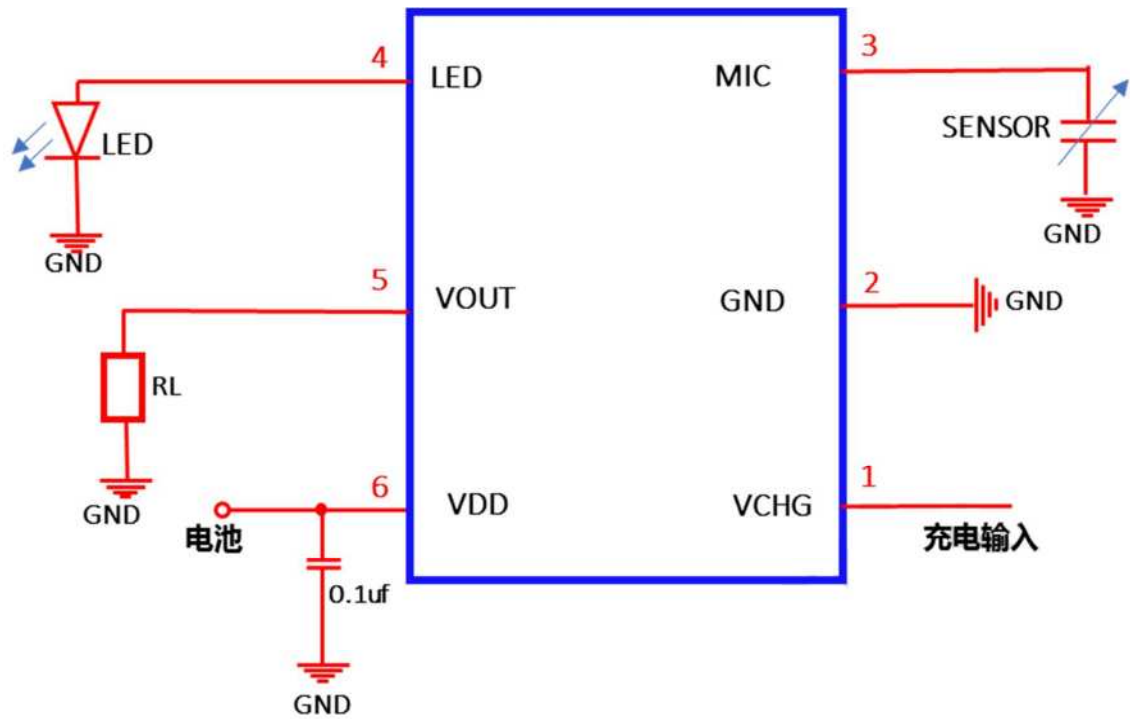

--	--	--	--



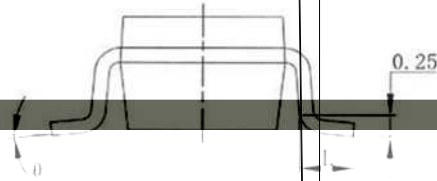
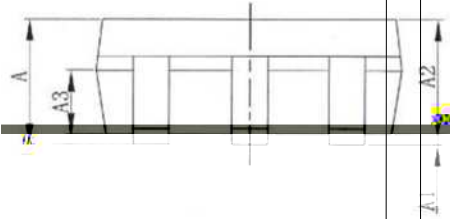

SYMBOL	MILLIMETER			
	MIN	NOM	MAX	
A	—	—	1.25	⚠
A1	0.04	—	0.10	⚠
A2	1.00	1.10	1.20	
A3	0.55	0.65	0.75	
b	0.38	—	0.48	
b1	0.37	0.40	0.43	
e	0.11	—	0.21	
e1	0.10	0.13	0.16	
D	2.72	2.92	3.12	
E	2.60	2.80	3.00	
E1	1.40	1.60	1.80	
e	0.95BSC			
e1	1.90BSC			
L	0.30	—	0.60	
θ	0	—	8°	

