



### Absolute Maximum Ratings at Ta=25

Parameter	MAX.	Unit
Power Dissipation	180	mW
Continuous Forward Current	100	mA
Peak Forward Current <sup>*2</sup>	1000	mA
Reverse Voltage	5	V
Electrostatic Discharge (HBM) <sup>*3</sup>	2000	V
Moisture Sensitivity Level <sup>*1</sup>	5a	
Operating Temperature	-40 to + 85	
Storage Temperature	-40 to + 100	
IR Reflow Temperature	260 for 10 Seconds MAX.	

**1. Storage and operating:**

- (1). Storage requirements before vacuum bag opened: Temperature<30

## Electrical Optical Characteristics at Ta=25

Parameter	Symbol	Min.	Typ.	Max.	Unit	Test Condition
Radiant Intensity	I <sub>e</sub>	1.7	2.0	---	mW/sr	I <sub>F</sub> =20mA (Note 1,3)
Viewing Angle	2 <sub>1/2</sub>	---	120	---	Deg.	(Note 2)
Peak Wavelength	λ <sub>p</sub>	---	940	---	nm	I <sub>F</sub> =20mA
Spectral Line Half- Width		---	50	---	nm	I <sub>F</sub> =20mA
Forward Voltage	V <sub>F</sub>	---	1.35	1.60	V	I <sub>F</sub> =20mA
Reverse Current	I <sub>R</sub>	---	---	10	μA	V <sub>R</sub> =5V

### Note:

1. Point sources of the amount of radiation per unit time in a given direction within the unit solid Angle radiated energy.
- 2 <sub>1/2</sub> is the off-axis angle at which the Radiant Intensity is half the axial Radiant Intensity.
3. The I<sub>e</sub> guarantee should be added ±15% tolerance.



## Typical Electrical / Optical Characteristics Curves (25 Ambient Temperature Unless Otherwise Noted)

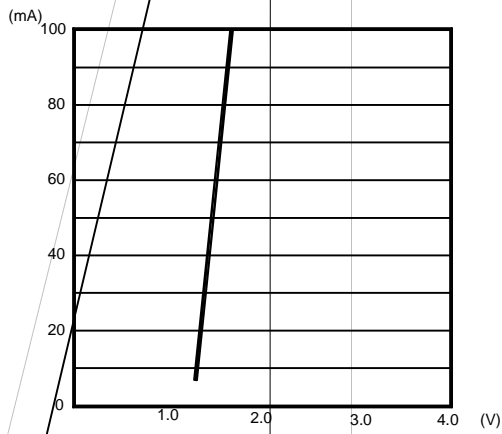

0.5

### Radiant Intensity Bin Code ( $I_F=20\text{mA}$ )

BIN CODE	Min.(mW/sr)	Max. (mW/sr)
0	1.7	1.8
1	1.8	2.0
2	2.0	2.3
3	2.3	2.8

**NOTE:** The  $I_e$  guarantee should be added  $\pm 15\%$  tolerance.

**LIGHT ELECTRONICS CO., LTD.**

## Carrier Tape Specifications (Loaded Quantity: 2000pcs/reel)

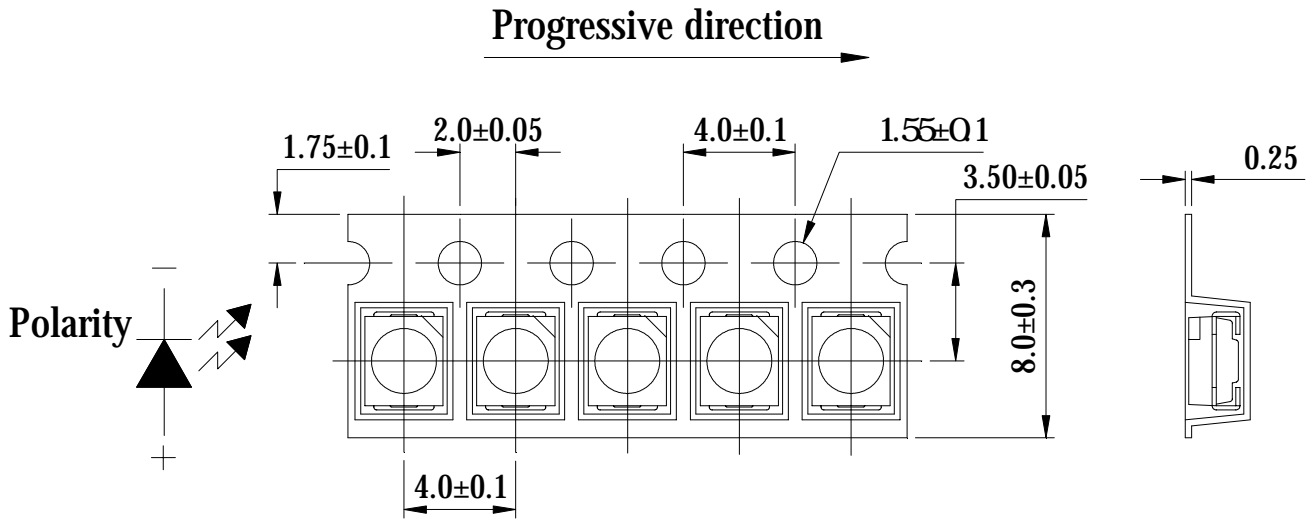

**Note:** Tolerance unless mentioned is  $\pm 0.1$ mm; Unit = mm

## Moisture Resistant Packaging



## Suggest IR Reflow Condition For Lead Free

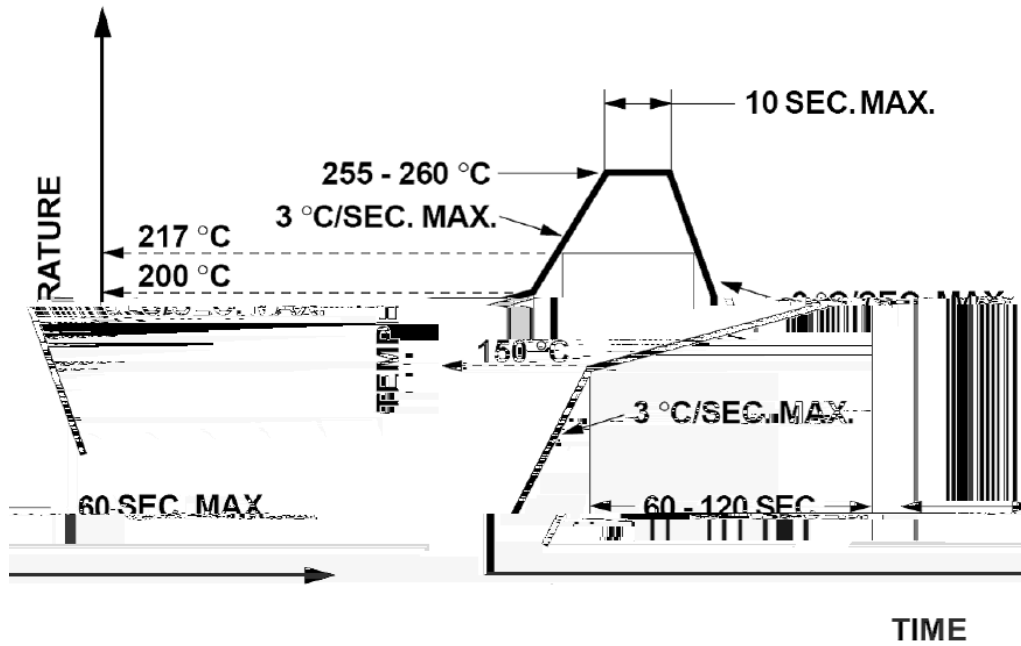

1. Reflow soldering should not be done more than two times.
2. When soldering, do not put stress on the LEDs during heating.

## Soldering iron

1. When hand soldering, the temperature of the iron must less than 300 for 3 seconds.
2. The hand solder should be done only once.

## Repairing

Repair should not be done after the LEDs have been soldered. When repairing is unavoidable, a double-head soldering iron should be used (as below figure). It should be confirmed beforehand whether the characteristics of LEDs will or will not be damaged by repairing.

